

DIMENSIONS

MAARTEN swivel base armchair smooth upholstery

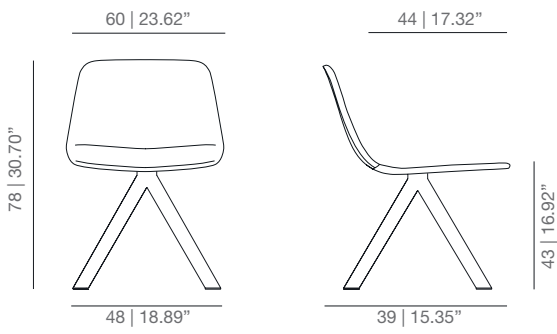

MAARTEN wood swivel base armchair smooth upholstery

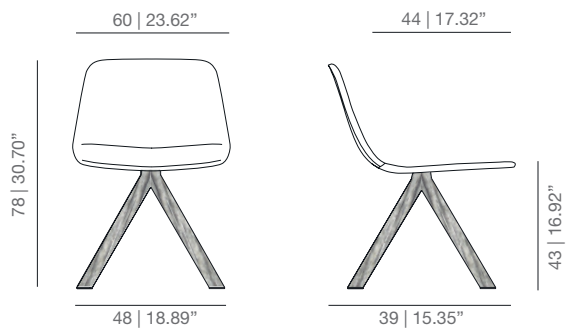

MAARTEN swivel base armchair soft upholstery

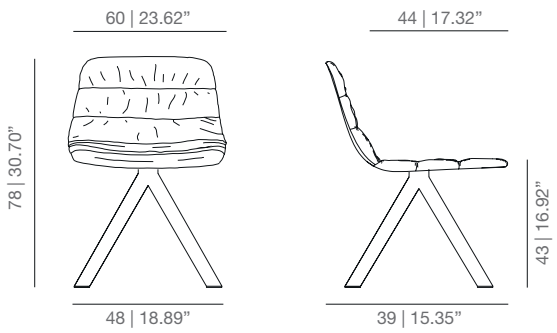

MAARTEN wood swivel base armchair soft upholstery

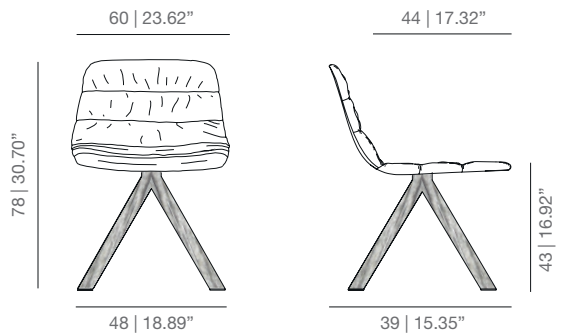

MAARTEN arms

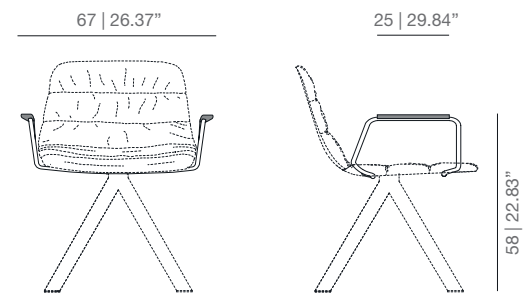

TECHNICAL INFO

Calibrated steel swivel structure powder coated in thermoreinforced polyester or calibrated steel with an oak veneer, available in all the collection's polishes.

Moulded shell in 3D surface veneer.

Expanded polyurethane foam.

Fabric or leather.

Transparent injection polypropylene tips.

Calibrated steel arms powder coated in thermoreinforced polyester in black, sand, altea blue or flourescent orange, with natural oak armrests.

FINISHES**UPHOLSTERY**

Check upholstery samples.

STRUCTURE | ARMS**Lacquered**

white
RAL 9003



black
RAL 9005



altea blue
RAL 5000



sand
NCS 3005Y50R



flourescent orange
RAL 2005

Stained

matt
oak



wenge



cognac



ash