



GUILLAUME DELVIGNE

SWAN

Pendant lamp ●● 2013



MATERIALS & FINISHES

FINISHES



Upper shade: Opaline white blown glass
Lower shade: chromed steel

DIMENSIONS & WEIGHT

	SWAN	WITH PACKAGING
HEIGHT	42cm/16,5in.	50cm/19,7in.
WIDTH	44cm/17,3in.	50cm/19,7in.
DEPTH	44cm/17,3in.	50cm/19,7in.
WEIGHT	8kg/17lbs.	9,5kg/21lbs.

Ø 44

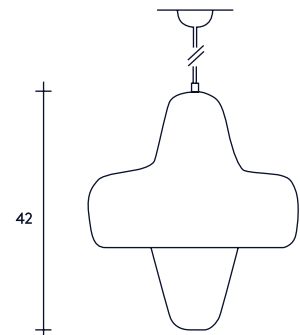

42



OTHER DETAILS

TECHNICAL INFORMATION

Delivery: in stock
E27/60W. Bulb not included.
Length of wire : 2,50m

Blown glass is an artisanal product and may present slight distortions.

PACKAGING

1 thick cardboard box

MAINTENANCE

Always use a microfiber cloth and rub lightly. Never use any solvents.