

REVISED 9/12/18

PRODUCT

JAX CHANDELIER
JAX 15-001

MATERIALS (FINISHES)

ANODIZED ALUMINUM (AGED
BRONZE, GOLDEN BRONZE, BLACK,
SILVER)

SOLID OPTIC CRYSTAL (CLEAR,
FROSTED, SMOKE)

WEIGHT

9.2 LBS

LAMPING

INTEGRATED LED (QTY 15)
1.3W, 3000K
ELV AND PHASE DIMMABLE

CERTIFICATIONS

ETL LISTED (120V)

NOTES

JAX IS COMPRISED OF MODULAR
COMPONENTS AND IS MEANT TO
BE ASSEMBLED ON-SITE BY A
QUALIFIED ELECTRICIAN AND
INSTALLATION PROFESSIONAL.



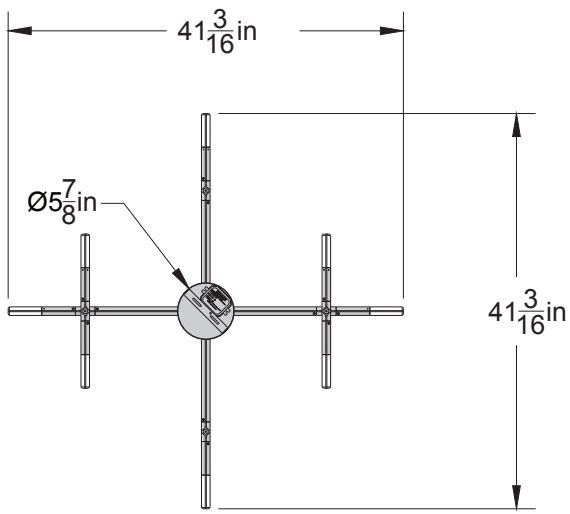

TOP VIEW

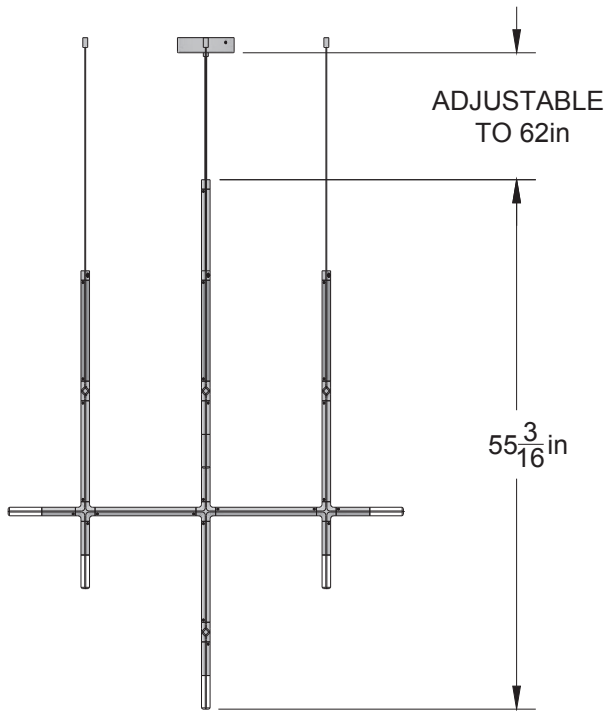

FRONT VIEW

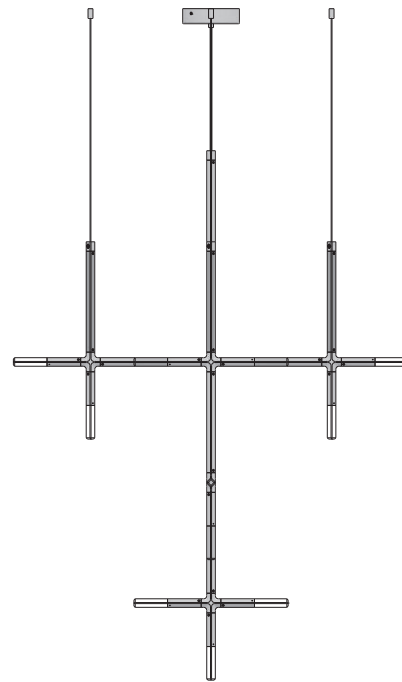

SIDE VIEW

© 2018, LAKE AND WELLS, LLC ALL RIGHTS RESERVED