

Colour combination - Zig - Zag

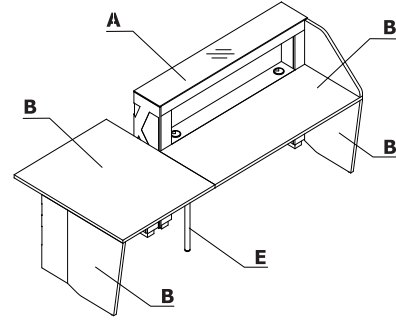
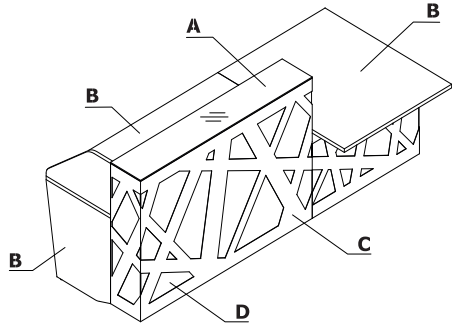

Material	Colour	All elements																
		A - Upper top	B - Body	C - Front - metal	D - Front - plexiglass	E - Supporting leg												
	117 - glass white - RAL 9003	✓																
	MFC - 67 - white pastel		✓															
	Metal - M015 - white semi-mat			✓		✓												
	Plexiglas - white				✓													

Technical specification

- 1 Top** - tempered optiwhite glass, 8 mm - painted on bottom side
- 2 Worktop** - MFC 28 mm, ABS edge
- 3 Front** - powder coated steel and plexiglas
- 4 Light source** - RGBW LED, remote control
- 5 Low side panel** - MFC 28 mm, ABS edge
- 6 Leveling** - 5 mm range
- 7 Cable grommets** - Ø80 mm
- 8 Supporting leg NL41** - required for connecting the tops
- 9 Side panel** - MFC 28 mm, ABS edge

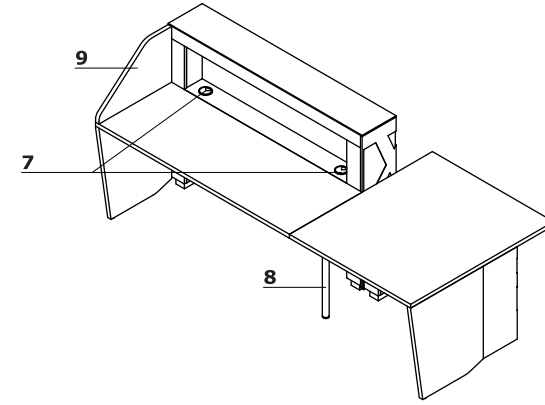
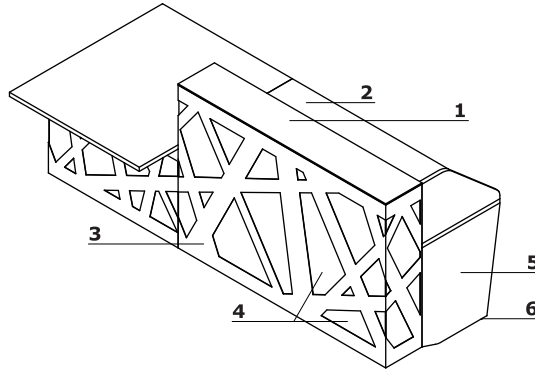

Dimensions (mm)

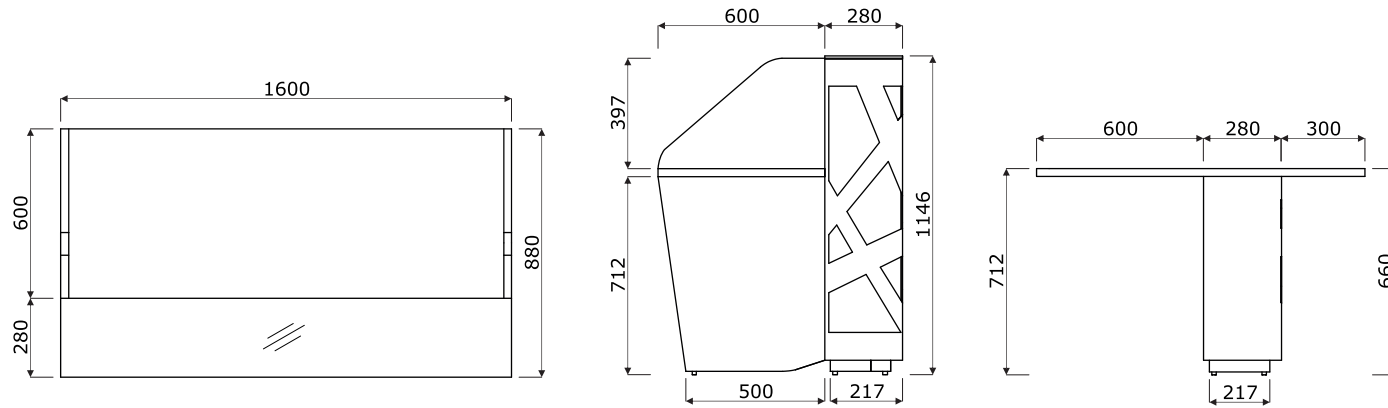

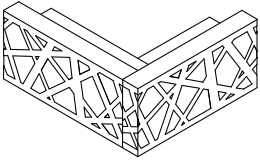
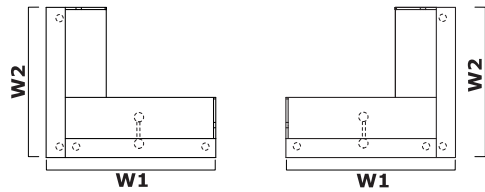
 		Dimensions					kg m3 pcs	Composition elements
		W1	W2	D1	D2	H		
LZG44		2480	2200	1622	850	1146	276.2 kg 3.224 m3 14 pcs	LZN51+LZB22+2xLZG22+LZB22M+NL41

Extra charge						

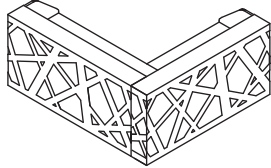
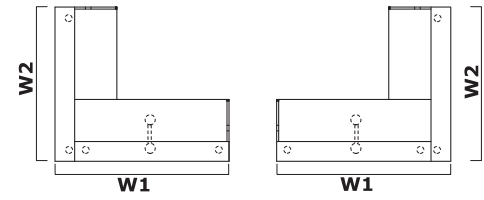
 		Dimensions					kg m3 pcs	Composition elements
		W1	W2	D1	D2	H		
LZG45		2480	2200	1622	850	1146	283.2 kg 3.243 m3 15 pcs	LZN51+LZK01+2xLZG22+LZB22 +LZB22M+NL41

Extra charge						

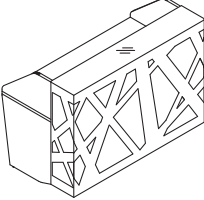
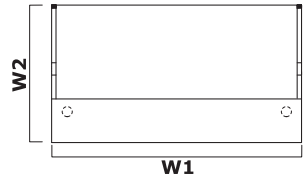
 		Dimensions					kg m3 pcs	Composition elements
		W1	W2	D1	D2	H		
LZG34		1600	880	1622	850	1146	126.901 kg 1.245 m3 7 pcs	LZN51+LZK01+LZG16+LZB16
LZG46		2200	880	1622	850	1146	156.9 kg 1.69 m3 8 pcs	LZN51+LZK01+LZG22+LZB22

Extra charge						

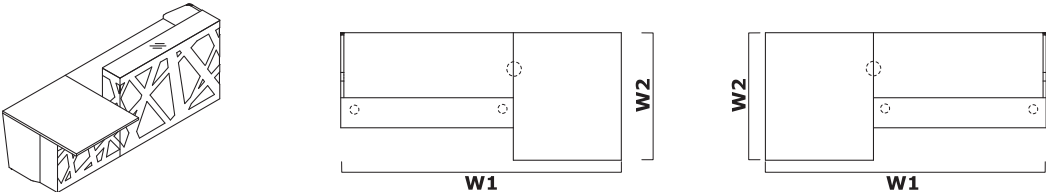

Symbol		Dimensions					kg m3 pcs	Composition elements
		W1	W2	D1	D2	H		
LZG50		2600	1180	1622	850	1146	208.401 kg 1.798 m3 11 pcs	LZN51+LZG10+LZG16+LZB16 +LZK01+NE41L
LZG51		3200	1180	1622	850	1146	238.4 kg 2.242 m3 12 pcs	LZN51+LZG10+LZG22+LZB22 +LZK01+NE41L

Extra charge					

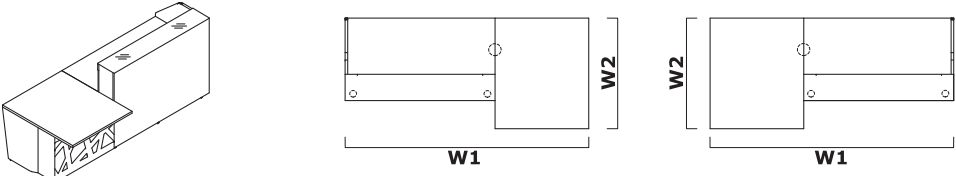

Symbol		Dimensions					kg m3 pcs	Composition elements
		W1	W2	D1	D2	H		
LZG56		2600	1180	1622	850	1146	210.401 kg 1.798 m3 11 pcs	LZG10+LZG16M+LZB16+LZN51 +LZK01+NE41L

Extra charge					

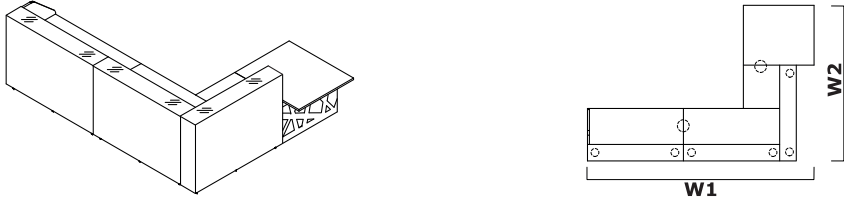

Symbol		Dimensions					kg m3 pcs	Composition elements
		W1	W2	D1	D2	H		
LZG57		3200	2880	1622	850	1146	419.202 kg 4.153 m3 23 pcs	LZN51+LZG10+LZB16M+2xLZB16+3xLZG16M+LZK01+2xNE41L

Extra charge					

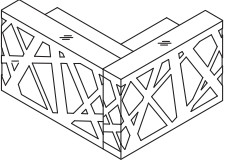
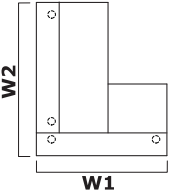
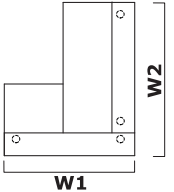
  		Dimensions					kg m3 pcs	Composition elements
		W1	W2	D1	D2	H		
LZG32		1600	1880	1622	850	1146	217.501 kg 2.386 m3 12 pcs	LZB16M+2xLZG16+LZB16+LZN51

Extra charge						

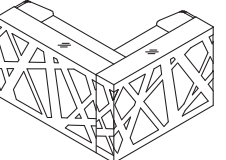
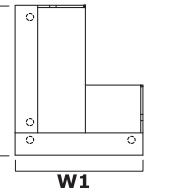
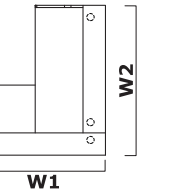
  		Dimensions					kg m3 pcs	Composition elements
		W1	W2	D1	D2	H		
LZG35		1600	1880	1622	850	1146	224.501 kg 2.405 m3 13 pcs	LZB16M+2xLZG16+LZB16+LZN51+LZK01

Extra charge						

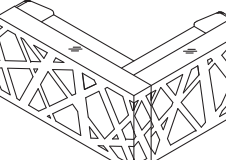
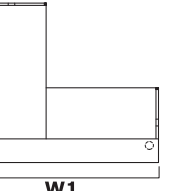
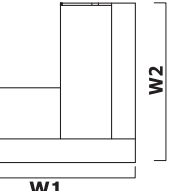
  		Dimensions					kg m3 pcs	Composition elements
		W1	W2	D1	D2	H		
LZG36		2200	1880	1622	850	1146	252.501 kg 2.799 m3 13 pcs	LZN51+LZK01+LZB22+LZG22 +LZB16M+LZG16

Extra charge						

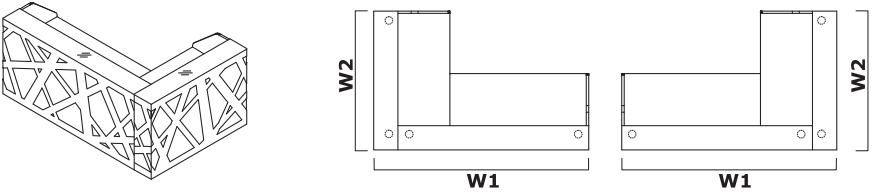
		Dimensions					kg m3 pcs	Composition elements
		W1	W2	D1	D2	H		
LZG38		2480	1600	1622	850	1146	245.501 kg 2.779 m3 12 pcs	LZN51+LZB16+LZG22+LZB22M +LZG16

Extra charge					

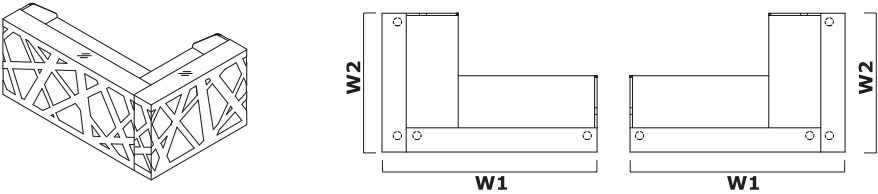
		Dimensions					kg m3 pcs	Composition elements
		W1	W2	D1	D2	H		
LZG40		2480	1600	1622	850	1146	252.501 kg 2.799 m3 13 pcs	LZN51+LZK01+LZB16+LZG22 +LZB22M+LZG16

Extra charge					

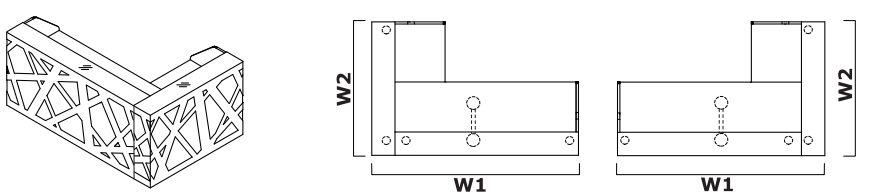
		Dimensions					kg m3 pcs	Composition elements
		W1	W2	D1	D2	H		
LZG42		2480	1600	1622	850	1146	252.4 kg 2.849 m3 11 pcs	LZN51+LZK01+LZB22+LZG22 +LZB16M+LZG16+NL41

Extra charge					

Symbol		Dimensions					kg m3 pcs	Composition elements
		W1	W2	D1	D2	H		
LZG58		3808	2880	1622	850	1146	415.202 kg 4.153 m3 23 pcs	LZN51+LZK01+2xLZB16+2xLZG16+LZG16M+LZB16M+LZG10N +2xNE41L

Extra charge						

Symbol		Dimensions					kg m3 pcs	Composition elements
		W1	W2	D1	D2	H		
LZG52		4200	1180	1622	850	1146	314.802 kg 2.991 m3 17 pcs	LZN51+LZK01+LZB16+LZG16 +LZG10+LZG16+LZB16+2xNE41L
LZG53		4800	1180	1622	850	1146	344.801 kg 3.435 m3 18 pcs	LZN51+LZK01+LZB16+LZG16 +LZG10+LZG22+LZB22+2xNE41L
LZG54		5400	1180	1622	850	1146	374.8 kg 3.88 m3 19 pcs	LZN51+LZK01+LZB22+LZG22 +LZG10+LZG22+LZB22+2xNE41L

Extra charge						

Symbol		Dimensions					kg m3 pcs	Composition elements
		W1	W2	D1	D2	H		
LZG55		4200	1180	1622	850	1146	307.802 kg 2.971 m3 16 pcs	LZN51+LZB16+2xLZG16+LZG10 +LZB16+2xNE41L

Extra charge						

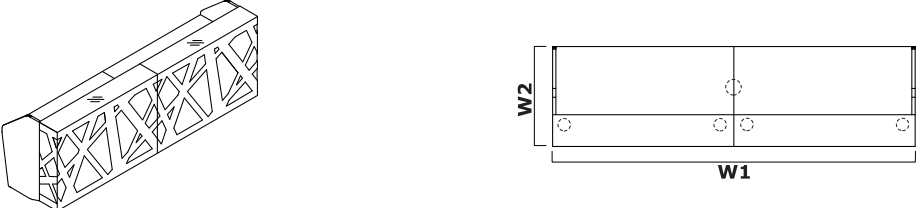

Symbol		Dimensions					kg m3 pcs	Composition elements
		W1	W2	D1	D2	H		
LZG60		3200	880	1622	850	1146	233.302 kg 2.438 m3 13 pcs	LZN51+LZK01+LZB16+LZG16 +LZB16+LZG16+NE41L
LZG61		3800	880	1622	850	1146	263.301 kg 2.882 m3 14 pcs	LZN51+LZK01+LZB16+LZG16 +LZB22+LZG22+NE41L
LZG62		4400	880	1622	850	1146	293.3 kg 3.327 m3 15 pcs	LZN51+LZK01+LZB22+LZG22 +LZB22+LZG22+NE41L

Extra charge						

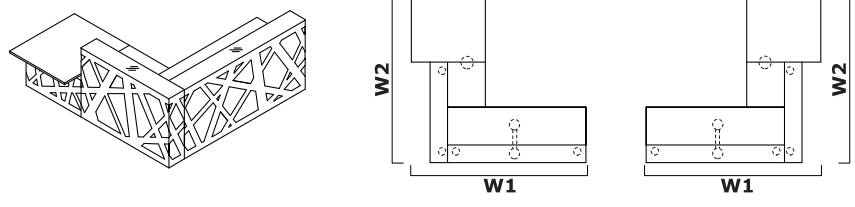

Symbol		Dimensions					kg m3 pcs	Composition elements
		W1	W2	D1	D2	H		
LZG64		2600	2780	1622	850	1146	328.3 kg 3.383 m3 16 pcs	LZN51+LZB22+LZG22+LZG16 +LZB16M+LZG10+NL41+NE41L

Extra charge						

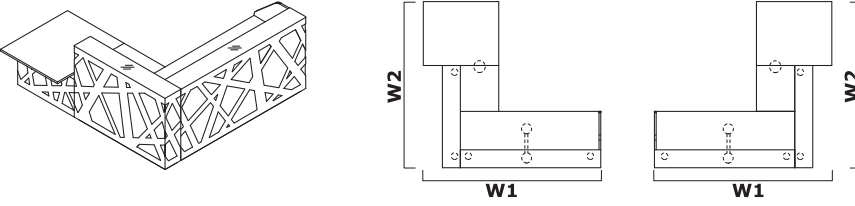

Symbol		Dimensions					kg m3 pcs	Composition elements
		W1	W2	D1	D2	H		
LZG63		2600	2780	1622	850	1146	335.3 kg 3.402 m3 17 pcs	LZN51+LZK01+LZB22+LZG22 +LZG16+LZG16M+LZG10+NL41+NE41L

Extra charge						

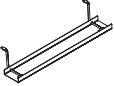
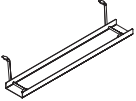
Composition elements							
	Symbol		Dimensions			kg m3 pcs	Comments
			Width	Depth	Height		
	NL41		585	142	712	2 kg 0.063 m3 1 pcs	round profile leg
	E64L		460	89	120	0.5 kg 0.001 m3 1 pcs	horizontal cable tray, M009 - aluminium semi-matt
	S69L		580	162	123	1 kg 0.015 m3 1 pcs	09 - aluminium

Extra charge						