

# MICHELLE WALL MIRROR

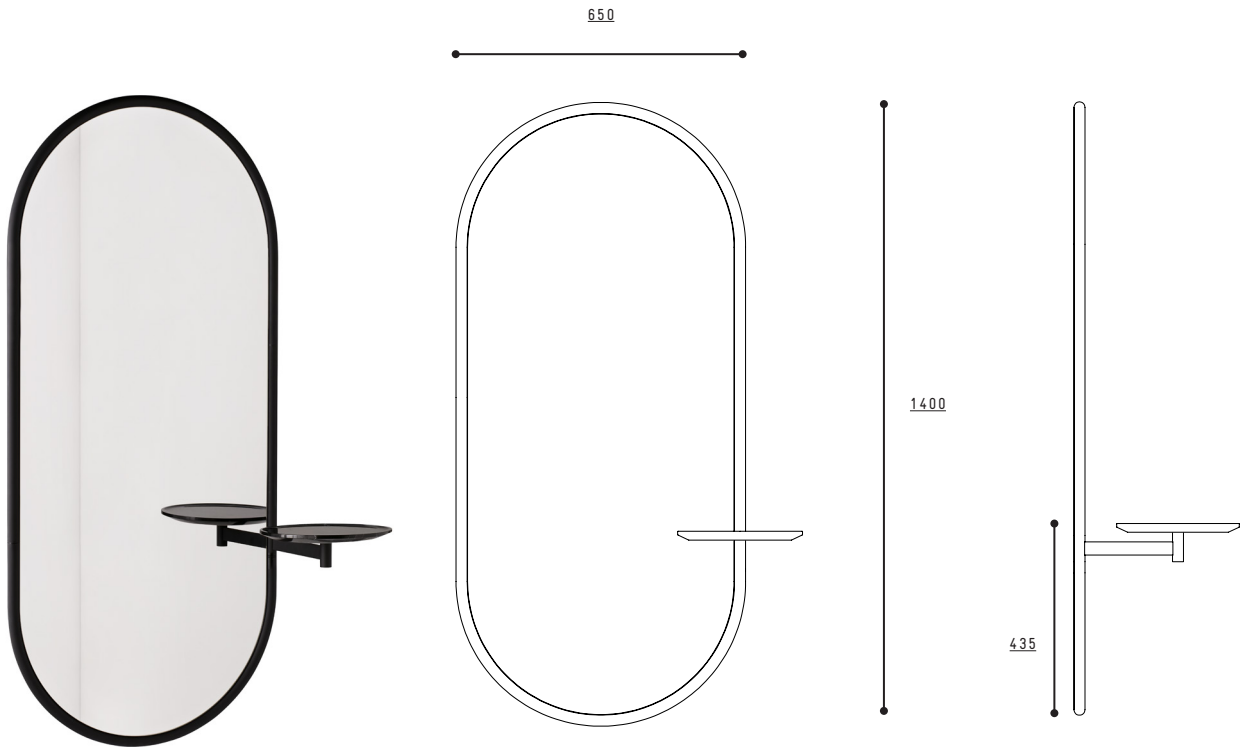

## MICHELLE WALL MIRROR

A FAMILY OF MIRRORS WITH COMMON FEATURES OF STEEL, SMOKED MIRROR AND MARBLE. MICHELLE IS GRACEFULLY DRAWN FROM A TUBULAR FRAME IN BRASS, PEWTER OR BLACKENED STEEL AND EMBELLISHED WITH A SERIES OF MARBLE TRAYS THAT MAKE IT THE PERFECT VALET.

## MATERIALS

FAMILY OF MIRRORS IN SMOKED FINISH WITH A FRAME CONSTRUCTED FROM FORMED STEEL TUBE AND FEATURE SERVICE ELEMENTS IN MARBLE. FRAME AVAILABLE IN POWDER COATED SATIN BLACK OR WITH A METALLIC LACQUERED BRASS OR PEWTER FINISH.

## DIMENSIONS

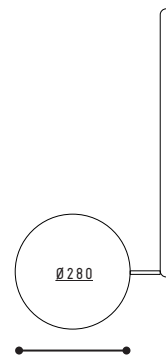

## DESIGNER

TIM RUNDLE

## CERTIFICATION

CATAS